



4A Bipolar TRIAC Series

Description

With low holding and latching current, this series triacs are especially recommended for use on middle and small resistance type power load.

Mechanical data

- Case: TO-220-3L
- Approx. Weight: 2.04g (0.07oz)
- Case: TO-220F-3L
- Approx. Weight: 1.767g (0.062oz)
- Lead free finish, RoHS compliant
- Case Material: "Green" molding compound, UL flammability classification 94V-0, "Halogen-free".

TO-220-3L(Suffix:C)

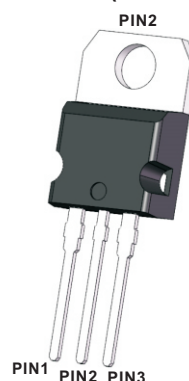

TO-220F-3L(Suffix:F)

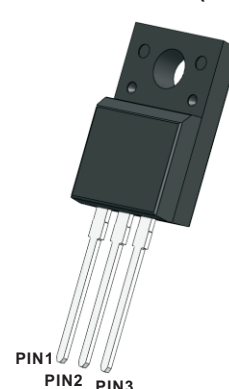

Application Circuit

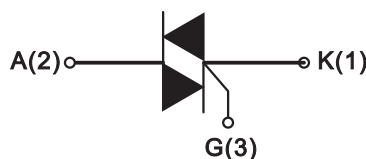

■ Absolute Maximum Ratings (Operating temperature range applies unless otherwise specified)

Parameter	Symbols	Ratings	Unit
Repetitive peak off-state voltage	V _{DRM}	600/800	V
Repetitive peak reverse voltage	V _{RRM}	600/800	V
Non repetitive surge peak Off-state voltage	V _{DSM}	V _{DRM} +100	V
Non repetitive peak reverse voltage	V _{RSM}	V _{DSM} +100	V
RMS on-state current	I _{T(RMS)}	4	A
Non repetitive surge peak on-state current (full cycle, f=50Hz)	I _{TSM}	35	A
I ² t value for fusing (tp=10ms)	I ² _T	6.1	A ² S
Critical rate of rise of on-state current	I-II-III	50	A/us
	IV	10	
Peak gate current (tp=20μs, Tj=125°C)	I _{GM}	2.0	A
Peak gate power (tp=20μs, Tj=125°C)	P _{GM}	5	W
Average gate power dissipation(Tj=125°C)	P _{G(AV)}	0.5	W
Operating junction temperature range	T _J	-40 to +125	°C
Storage junction temperature range	T _{STG}	-40 to +150	°C



■ Electrical Characteristics (T_J=25°C Unless Otherwise Specified)

Symbols	Test Condition	Quadrant		Value				Unit
				T*	D	E	F	
I _{GT}	V _D =12V	I-II-III	Max	5	5	10	25	mA
		IV		5	10	25	70	
V _{GT}		All		1.3				V
V _{GD}	V _D =V _{DRM} , T _j =125°C, R _L =3.3kΩ	All	Min	0.2				V
I _L	I _G =1.2 I _{GT}	I-III	Max	10	20	30	40	mA
		II-IV		15	35	45	60	
I _H	I _T =0.1A			5	15	25	30	mA
dV/dt	V _D =2/3V _{DRM} Gate Open T _j =125°C		Min	20	50	100	150	V/us
(dV/dt) _c	(dI/dt) _c =1.7A/ms T _j =125°C			0.1	0.1	0.5	5	V/us

■ Static Characteristics

Symbols	Parameter		Value(Max)	Unit
V _{TM}	I _{TM} =5.5A t _p =380μs	T _J =25°C	1.6	V
I _{DRM}	V _D =V _{DRM} V _R =V _{RRM}	T _J =25°C	5	uA
I _{RRM}		T _J =125°C	500	uA

■ Thermal Resistances

Symbols	Parameter		Value(Max)	Unit
R _{th(j-c)}	junction to case	TO-220-3L TO-220F-3L	2.5 3.3	°C/W

■ Ordering Information

T	4	C	-6	E	
↓	↓	↓	↓	↓	
T: TRIAC	4: I _T (RMS)	C: TO-220-3L F: TO-220F-3L	-6: 600V -8: 800V		
					T=I _{GT} 1-3≤5mA, I _{GT} 4≤5mA D=I _{GT} 1-3≤5mA, I _{GT} 4≤10mA E=I _{GT} 1-3≤10mA, I _{GT} 4≤25mA F=I _{GT} 1-3≤25mA, I _{GT} 4≤70mA



Package Outline
Through Hole Package ; 3 leads

TO-220-3L

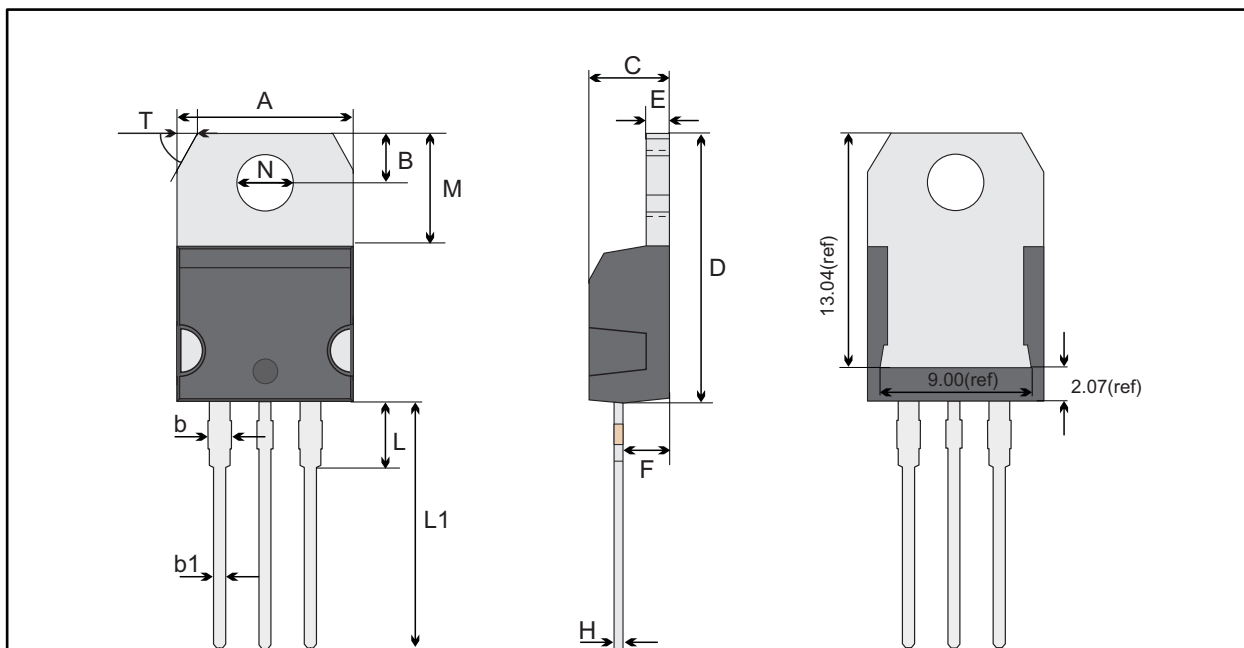

TO-220-3L mechanical data

UNIT		A	B	b	b1	C	D	E	F	G	H	L	L1	M	N	T
mm	max	10.28	2.84	1.67	0.9	4.65	15.54	1.37	2.79	2.64	0.6	3.88	13.13	6.39	3.82 typ.	1.19 58° ref.
	typ	10.18	2.74	1.47	0.8	4.45	15.34	1.27	2.59	2.54	0.5	3.68	12.93	6.19		
	min	10.08	2.64	1.27	0.7	4.25	15.14	1.17	2.39	2.44	0.4	3.48	12.73	5.99		
mil	max	405	112	66	35	183	612	54	110	104	24	153	517	252	150 typ.	47 58° ref.
	typ	401	108	58	31	175	604	50	102	100	20	145	509	244		
	min	397	104	50	28	167	596	46	94	92	16	137	501	236		

Marking Diagram

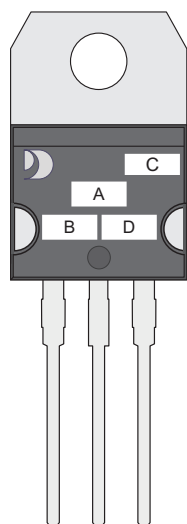

- Unmarkable Surfacea
- Marking Composition Field
- a: Ejector Pin Mark
- A: Marking Area
- B: Lot Code
- C: Additional Information
- D: Date Code (YWW)
- Y: Years(0~9)
- WW: Week



Package Outline
Through Hole Package ; 3 leads

TO-220F-3L

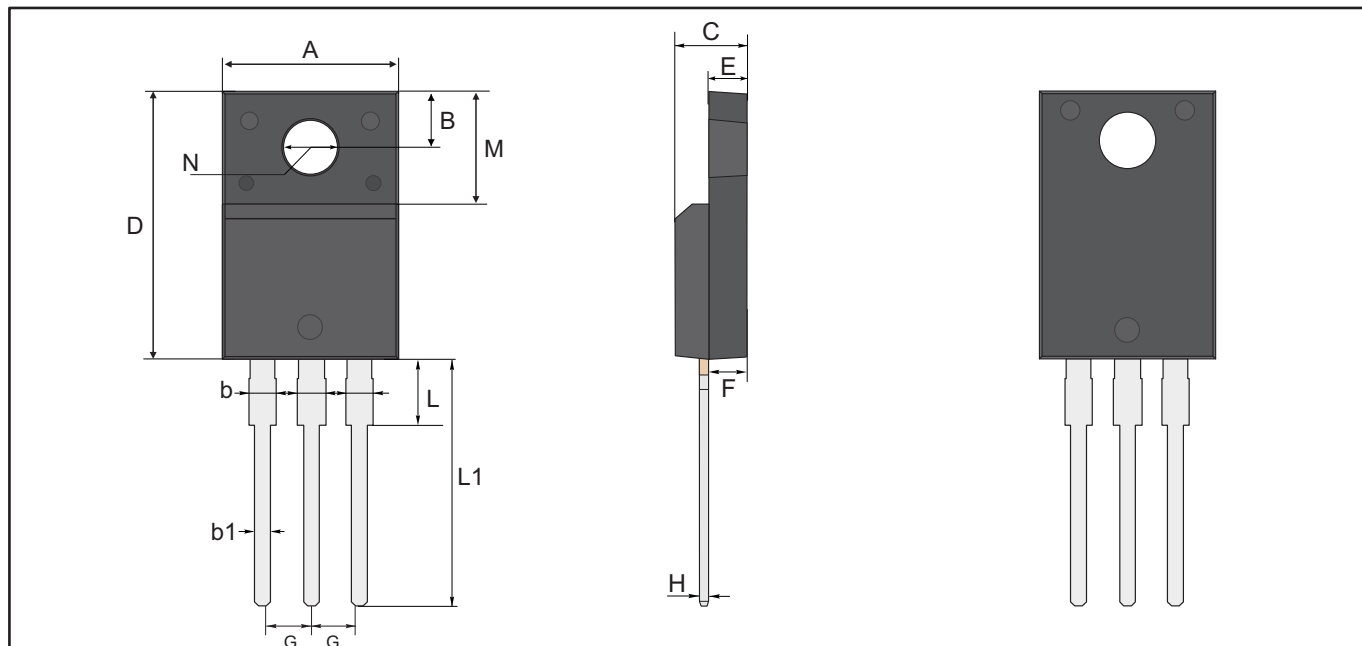

TO-220F-3L Mechanical data

UNIT		A	B	b	b1	C	D	E	F	G	H	L	L1	M	N
mm	max	10.28	3.37	1.44	0.9	4.9	16.07	2.74	2.74	2.64	0.6	2.85	13.7	6.98	3.18 typ.
	typ	10.18	3.27	1.34	0.8	4.7	15.87	2.54	2.54	2.54	0.5	2.65	13.5	6.68	
	min	10.08	3.17	1.24	0.7	4.5	15.67	2.34	2.34	2.44	0.4	2.45	13.3	6.38	
mil	max	405	133	57	35	193	633	108	108	104	24	112	539	275	125 typ.
	typ	401	129	53	31	185	625	100	100	100	20	104	531	263	
	min	397	125	49	28	177	617	92	92	96	16	96	524	251	

Marking Diagram

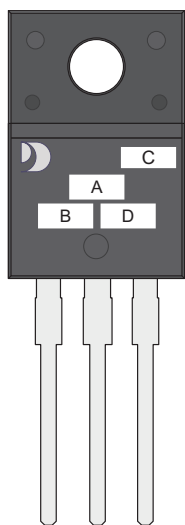

- Unmarkable Surfacea
- Marking Composition Field
- a: Ejector Pin Mark
- A: Marking Area
- B: Lot Code
- C: Additional Information
- D: Date Code (YWW)
- Y: Years(0~9)
- WW: Week



Important Notice and Disclaimer

Jingdao Microelectronics reserves the right to make changes to this document and its products and specifications at any time without notice. Customers should obtain and confirm the latest product information and specifications before final design, purchase or use.

Jingdao Microelectronics makes no warranty, representation or guarantee regarding the suitability of its products for any particular purpose, not does Jingdao Microelectronics assume any liability for application assistance or customer product design.

Jingdao Microelectronics does not warrant or accept any liability with products which are purchased or used for any unintended or unauthorized application.

No license is granted by implication or otherwise under any intellectual property rights of Jingdao Microelectronics.

Jingdao Microelectronics products are not authorized for use as critical components in life support devices or systems without express written approval of Jingdao Microelectronics.